

Colorado Procedure – Laboratory 4302-18

Standard Method of Test for

METHOD OF TEST FOR BONDING STRENGTH OF POLYESTER CONCRETE TO CONCRETE

1. SCOPE

- 1.1 This method covers the determination of the bonding strength of polyester concrete materials by a simple beam with center-point loading.

2. Referenced Documents

- 2.1 ASTM Procedures:
C78 Flexural Strength of Concrete (Using Simple Beam with Third Point Loading)
C305 Mechanical Mixing of Hydraulic Cement Pastes and Mortars of Plastic Consistency
C192 Making and Curing Concrete Test Specimens in the Laboratory

3. APPARATUS

- 3.1 Testing machine conforming to ASTM C 78
- 3.2 Apparatus for bonding test:
- 3.2.1 The Base Plate for this test shall be similar to the one specified in ASTM C 78 with a support length (L) of 9 in.
- 3.2.2 A diagram of the apparatus and load-applying bar is shown in Figures 1 and 2. The load-applying bar shall provide a uniform point load along the length of the bond interface.
- 3.3 Electrically driven mechanical mixer with paddle and mixing bowl, as specified in ASTM C305, Sections 4.1, 4.2, and 4.3.
- 3.4 Concrete mixer, scales, tamping rods, miscellaneous equipment and molds shall conform to ASTM C 192. The molds shall have internal dimensions of 3 in. × 3 in. × 12 in.

4. SPECIMEN FABRICATION

- 4.1 PCC Blocks. Portland cement concrete blocks shall be made from aggregate passing the 3/8 in. sieve. The concrete mix shall have a nominal cement content of 675 lb/yd³, achieve a minimum compressive strength of 4,500 psi in 28 days and have an air content of 5 to 7 %.
- 4.1.1 Prepare the materials according to ASTM C192
- 4.1.2 Mix the concrete according to ASTM C192
- 4.1.4 Cast the concrete beams according to ASTM C192

- 4.1.3 Initial cure the concrete according to ASTM C192 for 1 day
- 4.1.4 Moist cure the concrete according to ASTM C192 until the concrete is 28 days old.
- 4.1.5 Remove the PCC Blocks from the moist room and place in dry storage. PCC blocks shall be aged for 6 months prior to use.
- 4.2 PCC Block Sample Preparation:
 - 4.2.1 Cut the PCC blocks approximately in half with a concrete saw with a water-cooled, diamond matrix cutting edge blade. The saw cut shall be at right angles to the length of the block. Care shall be taken to avoid contamination of the cut face, especially with oil.
 - 4.2.2 Wash the PCC blocks with clean water to remove all loose particles.
 - 4.2.3 PCC blocks shall be placed in a rustproof container and covered with a minimum of 1 in. of water for a minimum of 48 hr prior to use..
 - 4.2.4 Remove PCC blocks from the water, rinse them with clean water and dry them with a clean paper towel.
 - 4.2.5 Apply $\frac{3}{4}$ in. wide masking tape around the perimeter of the cut face. The tape application shall be even with the cut face and not protrude more than $\frac{1}{32}$ in. beyond the cut face.
 - 4.2.6 Place the taped block into a 3 in. \times 3 in. \times 12 in. mold coated with a suitable mold release. The cut face shall be not less than 5 in. from the end of the mold. Secure the block in the mold.

Note 1: A mixture of one part paste wax dissolved in 2 to 3 parts toluene is a suitable mold release.
 - 4.2.7 Cover the SSD bond blocks with a damp towel until ready to place the material to be tested. This is done to retain the SSD condition of the block.
- 4.3 Bond Test Sample Fabrication:
 - 4.3.1 Temperature of the air in the vicinity of the mixing area, the dry materials, molds, base plates, and mixing bowl shall be maintained from 68 to 77°F.
 - 4.3.2 Follow the material suppliers' instructions for applying a bonding coat to the bond surface of the PCC sample block in the mold.
 - 4.3.3 Mix the polyester concrete as specified by the manufacturer in the electric mixer or by hand in a batch of such size to yield 10 % excess after molding test specimens. Follow the manufacturer's recommendations as to the order of addition and mixing times. Materials shall be mixed thoroughly in the time allotted.
 - 4.3.4 Begin molding the specimens within 1 min after completion of the mixing.

- 4.3.5 Place the batched material in the mold in two equal layers. Compact each layer with a wooden tamper approximately $\frac{3}{4}$ in. \times 3 in. \times 18 in., 20 strokes for each layer or until a homogeneous specimen is obtained.
- 4.3.6 Spade the PCC bond block-bonding surface with a spatula to effect maximum contact of the batched material with the PCC.
- 4.3.7 Jig the mold between each layer to remove entrapped air.
- 4.3.8 Compact and strike off the material to the top of the mold, and finish to a smooth surface with a steel trowel.
- 4.3.9 Cure the material according to the manufacturer's recommendations.

5. PROCEDURE

- 5.1 Turn the test specimen on its side with respect to its position as molded so the top as molded is facing the operator.
- 5.2 Center the bond face line on the support block.
- 5.3 Center the loading system in relationship to the applied force.
- 5.4 Lower the spherical head of the testing machine until there is just enough clearance between the spherical head and the test specimen to permit insertion of the load-applying bar without it tipping over. The load-applying bar shall be placed directly on the bond face line of the specimen.
- 5.5 Apply the load continuously at a rate of 1500 lb/min until the specimen breaks. The specimen will break at the bond line, in the PCC or in the material being tested.
- 5.6 Calculate the modulus of rupture in bond as follows:

$$R = \frac{3Pl}{2bd^2}$$

Where:

R = modulus of rupture, psi

P = maximum applied load, lb

l = span length, in.

b = average width of specimen at the point of fracture, in.

d = average depth of specimen at the point of fracture, in.

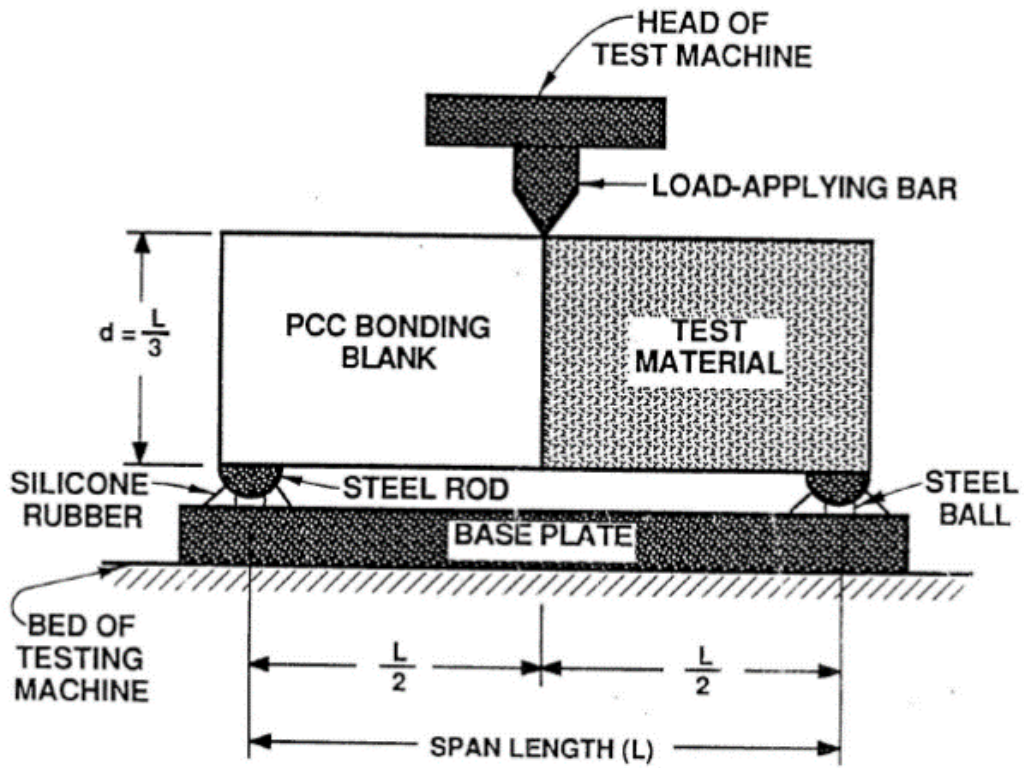
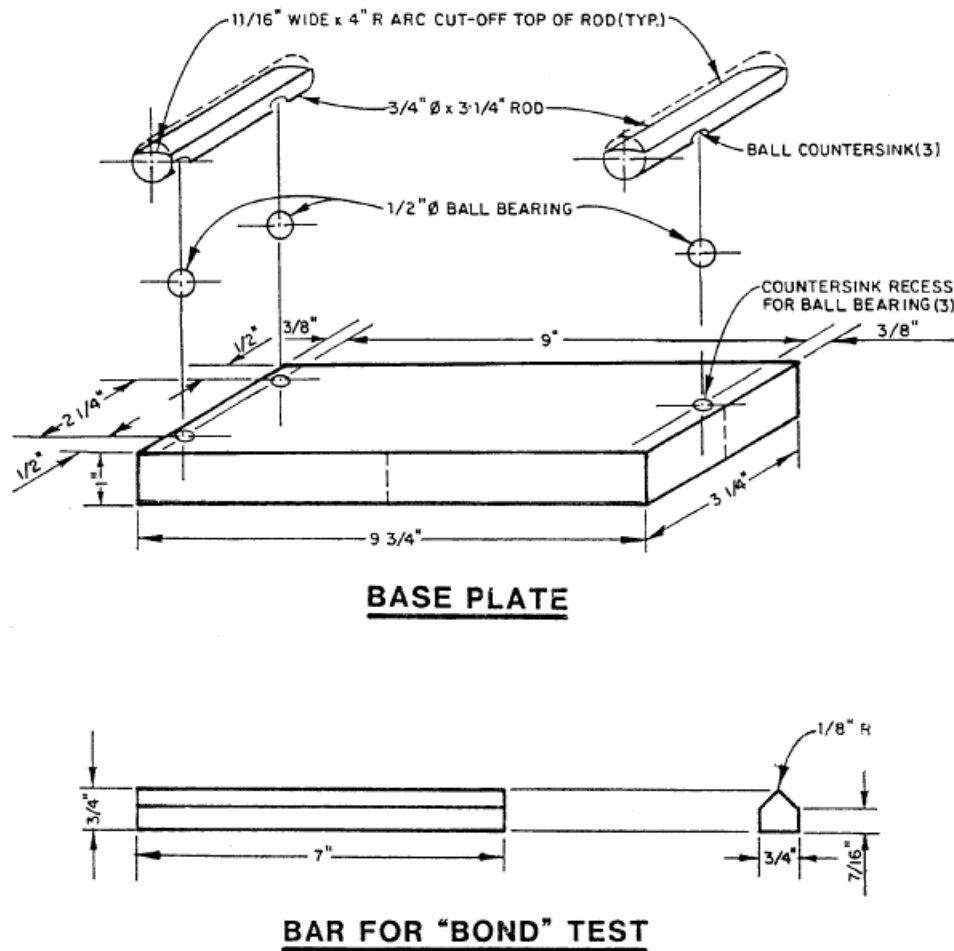

Figure 1 Apparatus for Bonding Strength Test in Center Point Loading



NOTE:

1. Ball bearings silver soldered to counter-sink in 3/4 in. diameter x 3 1/4 in. rod.
2. Rods cemented to base with silicon rubber.

Figure 2 Plan of Apparatus for Bond Test of Concrete Overlay and Patching Materials

{Page Intentionally Left Blank}